

REF: # 12659

()



INFO

PRICE:	364.000 €
PROPERTY TYPE:	Apartment
LOCATION:	()
BEDROOMS:	2
Bathrooms:	2
Build:	46 (m2)
Plot:	-
Terrace:	47 (m2)
Year:	-
Floor:	-
Old price	-

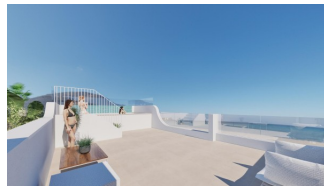

DESCRIPTION

Modern Living Steps from Las Higuericas Beach in Torre de la Horadada Prime Location Near the Mediterranean Coast Experience the best of coastal living with this stunning new development located just 150 meters from Las Higuericas Beach in Torre de la Horadada. Known for its golden sands and crystal-clear waters, this beachside town offers a perfect blend of relaxation and modern amenities. Whether you're seeking a tranquil retreat or a vibrant lifestyle, Torre de la Horadada provides the ideal setting for your dream home.

Thoughtfully Designed Residences Choose from modern ground-floor bungalows with private gardens or top-floor bungalows featuring spacious solariums. Each 2-bedroom property is designed with contemporary aesthetics and functionality in mind, offering:

- Private parking spaces.
- Large terraces for outdoor enjoyment.
- Premium features that enhance comfort and convenience.

Exceptional Community Amenities The development boasts an array of communal features designed to elevate your living experience:

- Landscaped green spaces for relaxation.
- A refreshing communal swimming pool.
- A paddle court for sports enthusiasts.
- Convenient lift access from the underground parking.

Premium Features for Modern Comfort Every home is equipped with high-quality finishes, including:

- Security entrance doors for peace of mind.
- Windows with thermal break for enhanced sound insulation.
- Fitted wardrobes with LED lighting.
- Pre-installed ducted A/C for year-round comfort.
- Elegant bathroom fixtures, mirrors, and glass shower screens.
- Electric blinds and exterior lighting for added convenience.
- Aerothermal water heaters for energy efficiency.

Convenient Access to Local Attractions This development's prime location ensures easy access to a variety of attractions and amenities:

- Las Higuericas Beach: Just 150 meters away for effortless beach days.
- Murcia Airport: 30 km (approximately 30 minutes by

car). Lo Romero Golf Course: 10 km, ideal for golf enthusiasts. Dos Mares Shopping Center: 11 km, offering shopping, dining, and entertainment. Port of San Pedro del Pinatar: 8 km, perfect for enjoying waterfront activities. Your Dream Home Awaits in Torre de la Horadada Embrace the unique lifestyle of Torre de la Horadada, where modern design meets Mediterranean charm. Don't miss your chance to own a home in this exclusive community. Contact us today to learn more or schedule a visit!

VIEWS

- Panoramic views

AIRCONDITIONING

- Central airconditioning

PARKING

Parking no Cars: 1

GARDEN AND TERRACES

- Fruit trees
- Fenced

EXTRA

- Lift

PROPERTY GALLERY















FASE 1

FASE 2

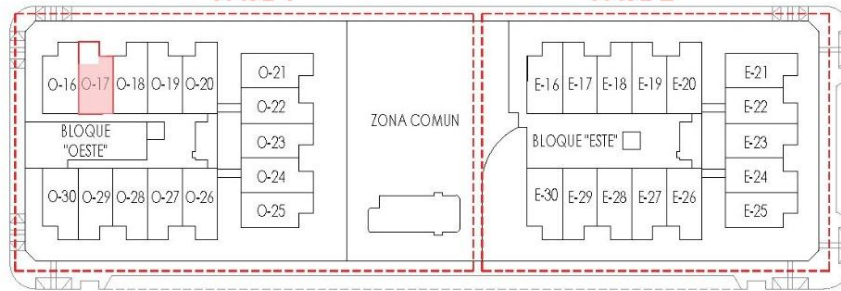

**BLOQUE OESTE
VIVIENDA O-17**

VIVIENDA 2 DORMITORIOS (P1)	
ESTANCIAS	SUPERFICIE
S. CONST VIVIENDA	46,33
S. CONST TERRAZA JARDÍN	7,84
SUP SOLARIUM	40,00
PARKING PLAZA N:17	15,81
TOTAL	109,98



PLANTA PRIMERA

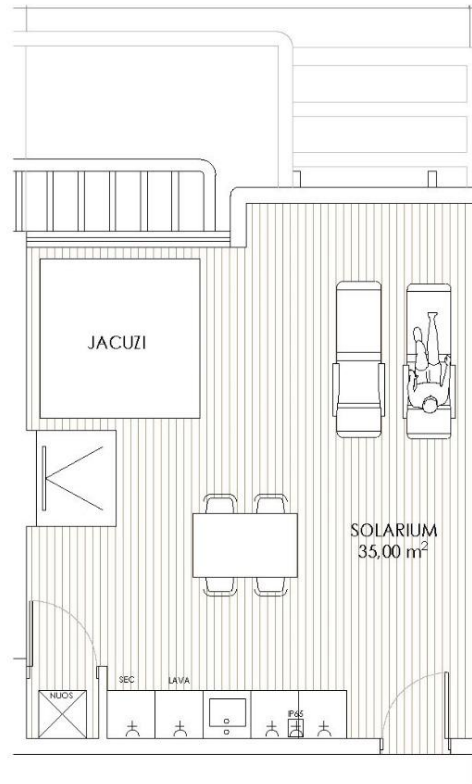

PLANTA SOLARIUM

BLOQUE OESTE - PLANTA PRIMERA : VIVIENDA O-17



FASE I (30 VIVIENDAS)

- ALTAS (015 - 030)
- BAJAS (01 - 015)

■ ALTAS (E15 - E30)

■ ÁTICOS (E31 - E34)

FASE II (34 VIVIENDAS)

■ BAJAS (E1 - E15)

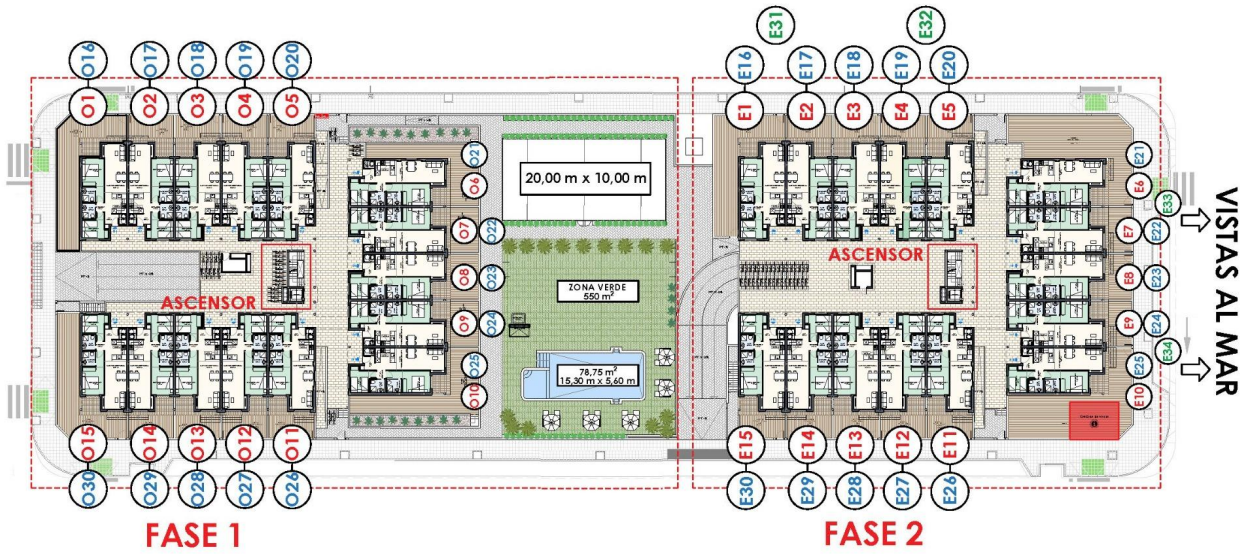

PLANO GENERAL

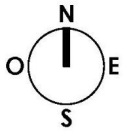

- * PISCINA
- * GARAJE SUBTERRÁNEO
- * PISTA DE PADEL
- CON PARKING INCLUIDO
- * ASCENSOR



"Experience our experience - Because you deserve the best"